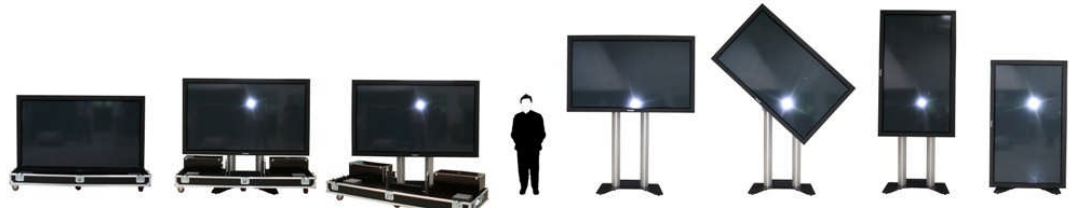

**SCREENLIFTER  
98 LITE****DISPLAY SYSTEM**

Das MediaScreen ScreenLifter 98 LITE model is the robust and cost-effective alternative to ScreenLifter 103 Classic. The ScreenLifter 98 LITE was developed specifically for the needs of AV rental companies such as a robust and scratch-resistant surface coating. However even the ScreenLifter 98 LITE makes the handling and setup of the large-screen-displays becomes a mere child's play. Touching a button and the display-system unloads itself out of the flight case. Thanks to the heavy duty and precise drive unit, the installation-height of the display is continuously variable and the display even can be rotated for vertical setups. The ScreenLifter 98 LITE with its integrated shock absorbing system combines a secure and convenient storage and transport system that allows the tool-free setup of the display by just one person. The display is permanently attached to the Screen Lifter 98 LITE, which significantly reduces the risk of damage during handling and saves precious time and cost of labour.

No compromises were made in the development of the ScreenLifter 98 LITE to meet the targets of perfect function and economically design. The flight case fits through a standard door frame, which makes it possible to set up the ScreenLifter 98 LITE in virtually any location. The wired remote control panel features a LED display that shows the height of the display centre.

**FEATURES & FUNCTIONS**

- Functional design stand for 98" displays.
- Electrical self up- and unload function.
- Tool free setup by only 1 person in a few minutes.
- Secure transport system with shock absorbing system.
- Step less electrical height adjustment and 90° rotate function.
- Robust steel and aluminum construction.
- Made in Germany.



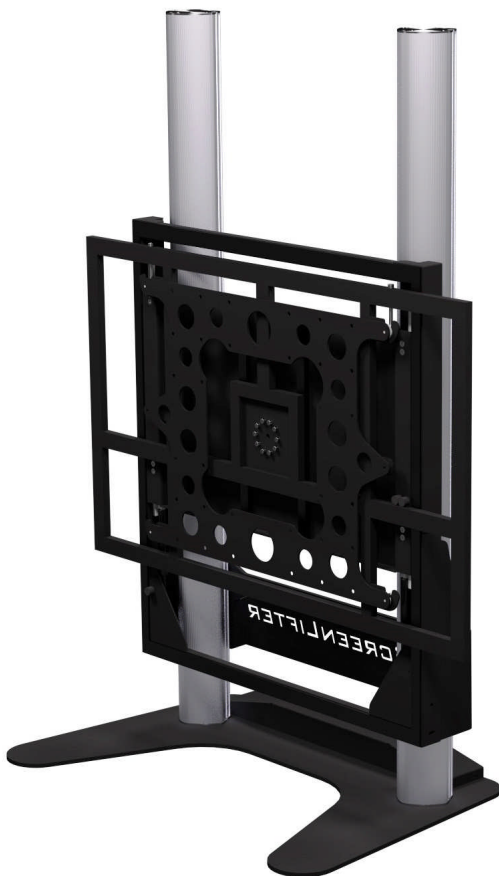

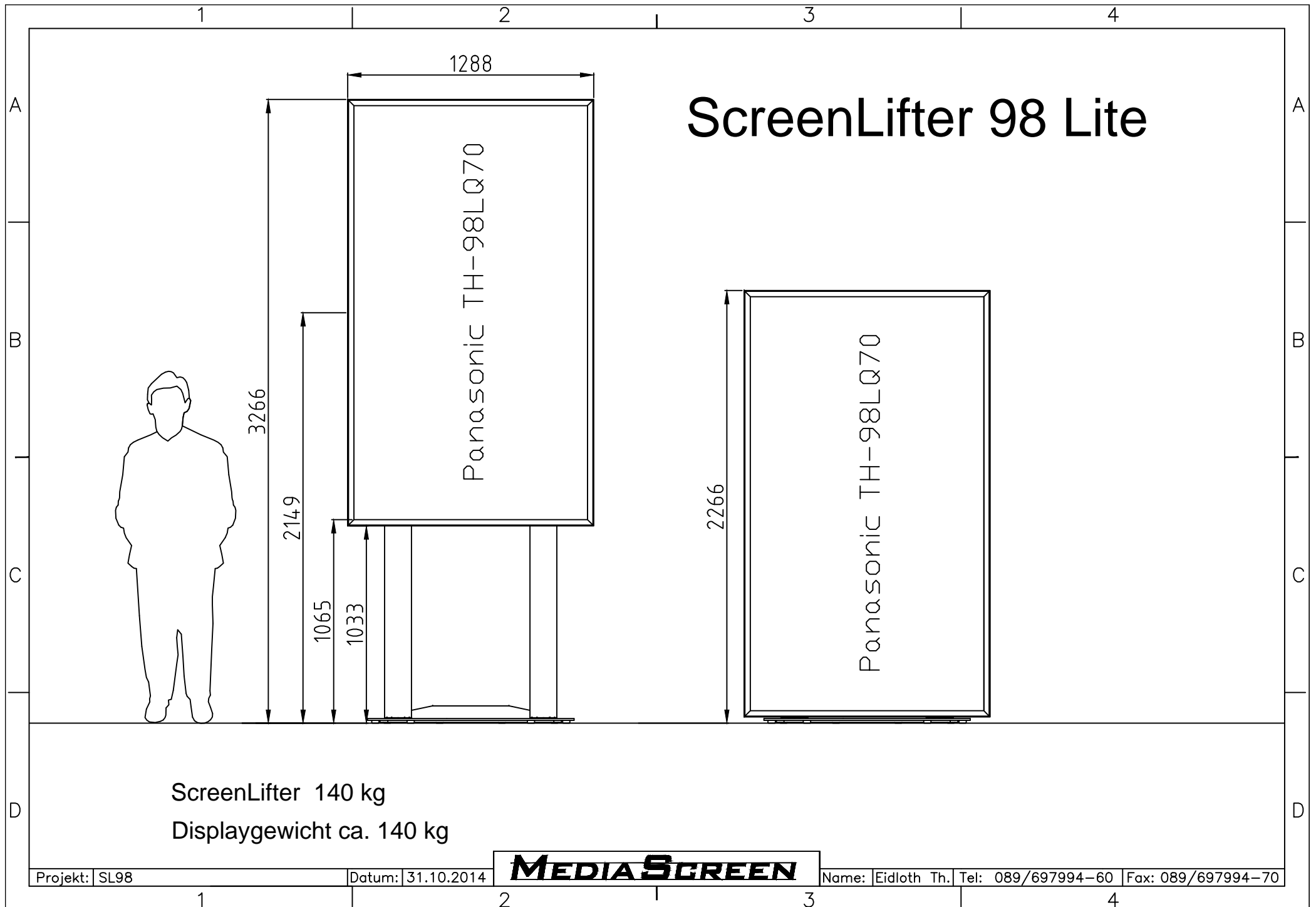

# ScreenLifter 98 Lite

Panasonic TH-98LQ70

Panasonic TH-98LQ70

ScreenLifter 140 kg  
 Displaygewicht ca. 140 kg

**MEDIA SCREEN**

Projekt: SL98

Datum: 31.10.2014

Name: Eidloth Th. Tel: 089/697994-60 Fax: 089/697994-70

# ScreenLifter 98 Lite

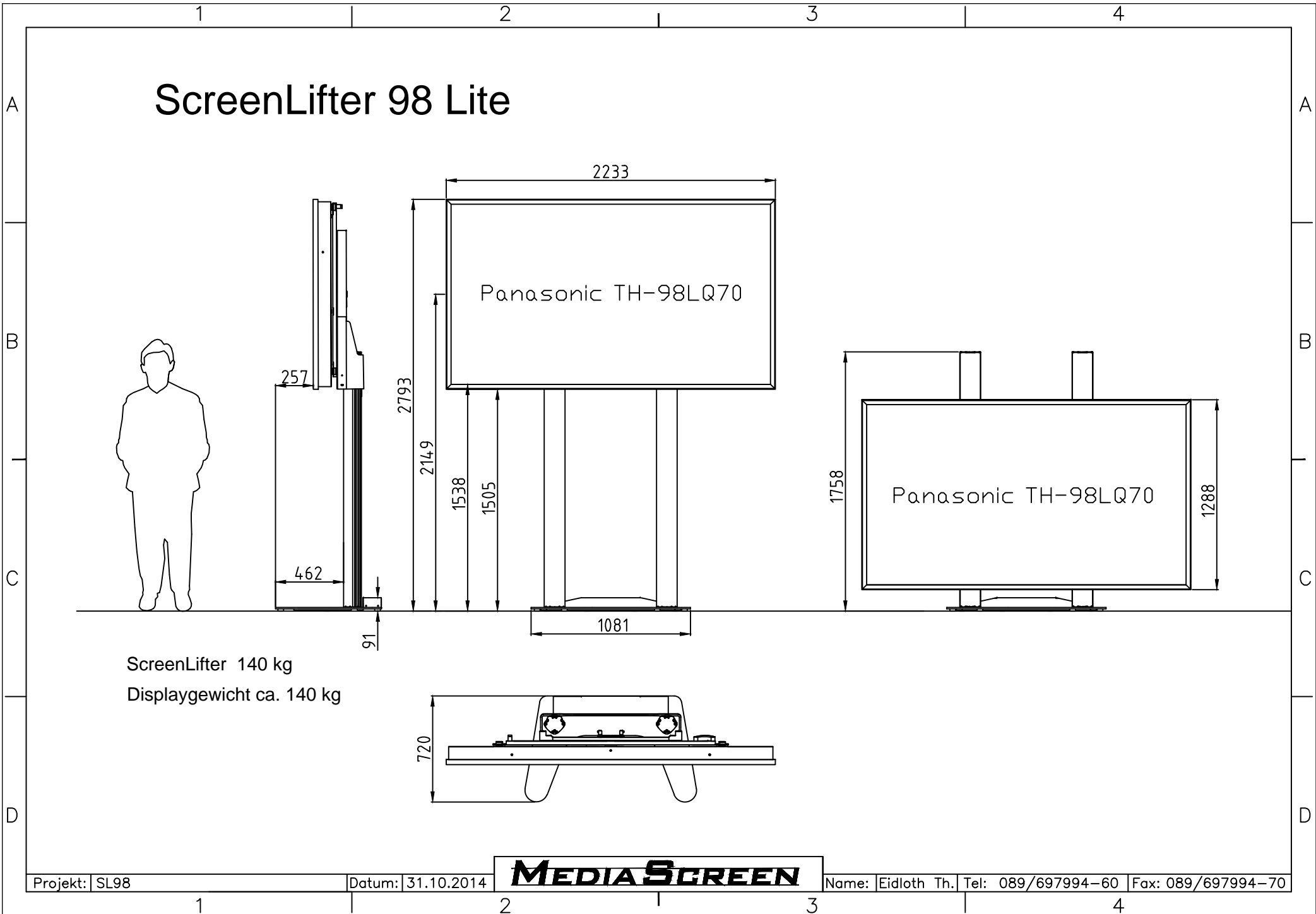

ScreenLifter 140 kg  
Displaygewicht ca. 140 kg

**MEDIA SCREEN**

Projekt: SL98

Datum: 31.10.2014

Name: Eidloth Th.

Tel: 089/697994-60

Fax: 089/697994-70

# Case SL98 Lite ECO

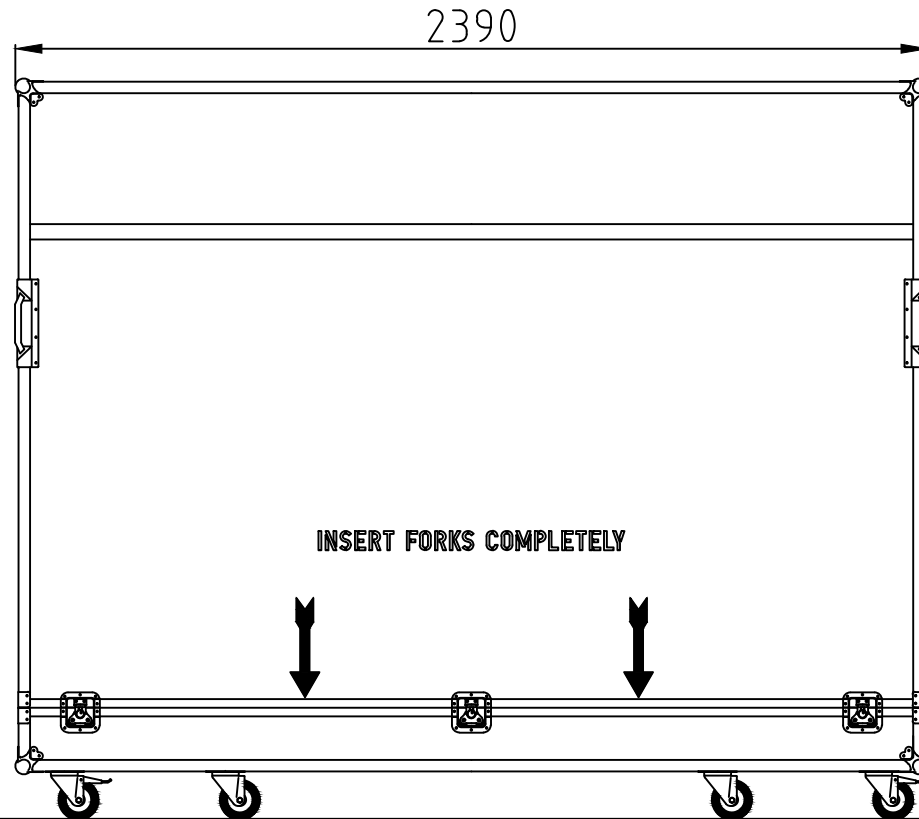
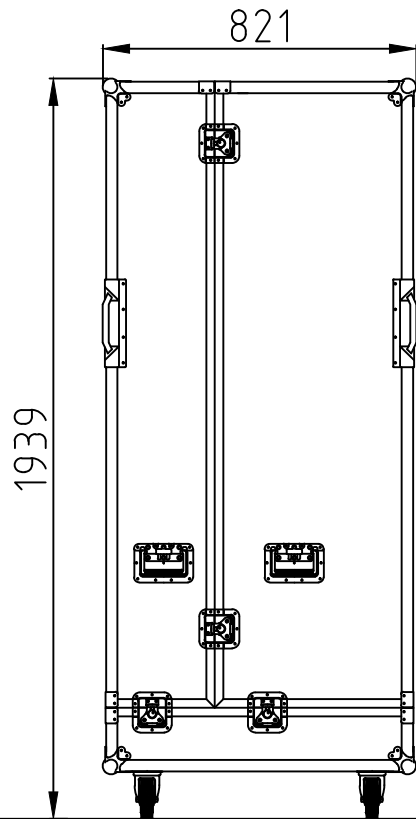

# ScreenLifter 98 Lite

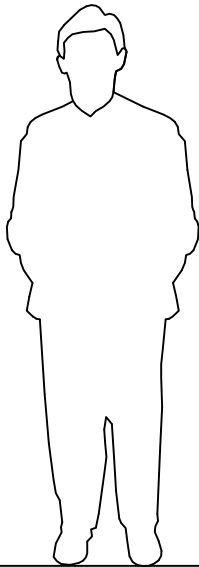

3237

2134

1055

1032

NEC X981 UHD

2238

NEC X981 UHD

ScreenLifter 140 kg

Displaygewicht ca. 95 kg

Projekt: SL98

Datum: 31.10.2014

**MEDIA SCREEN**

Name: Eidloth Th. Tel: 089/697994-60 Fax: 089/697994-70

# ScreenLifter 98 Lite

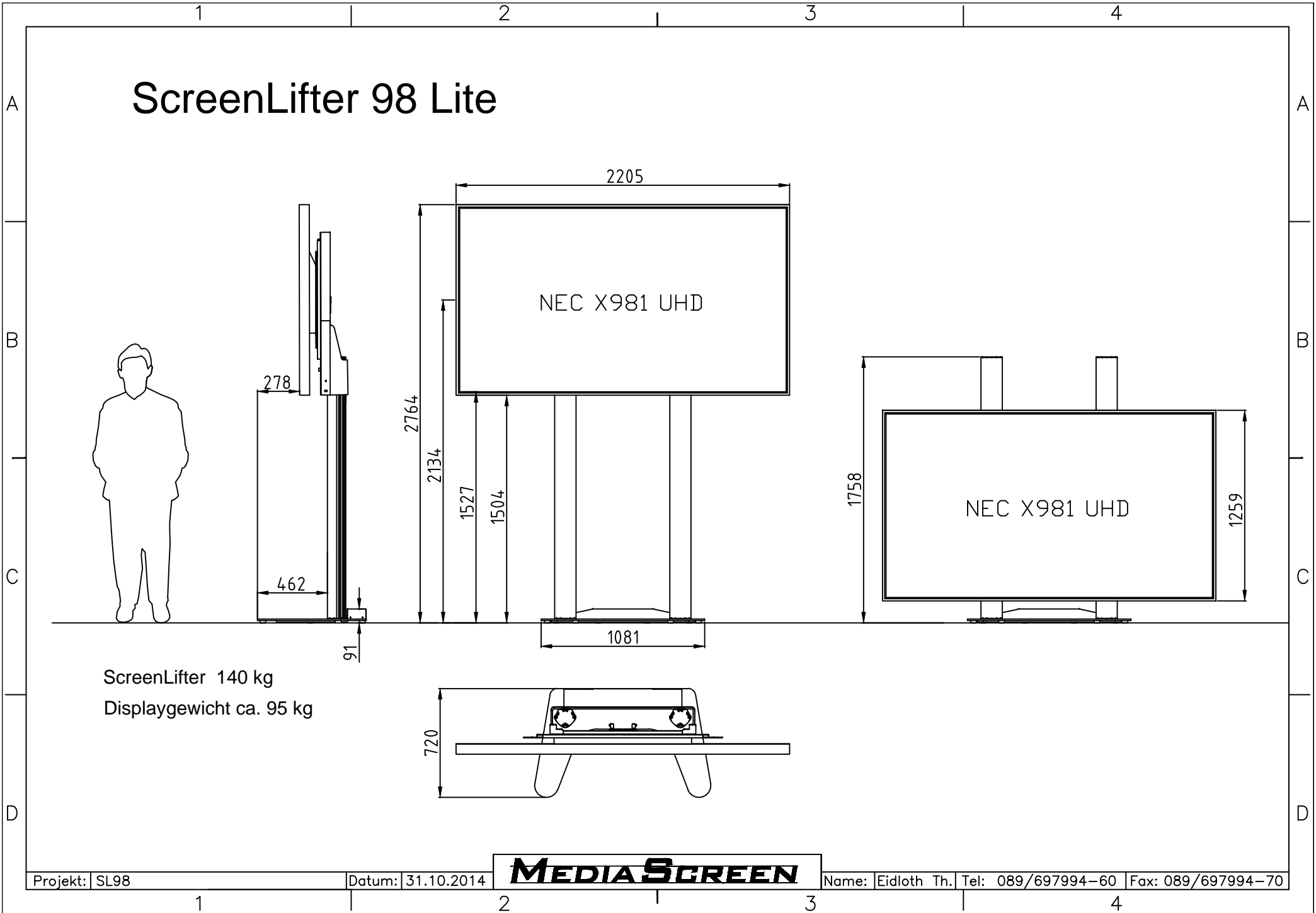

# Case SL98 Lite ECO

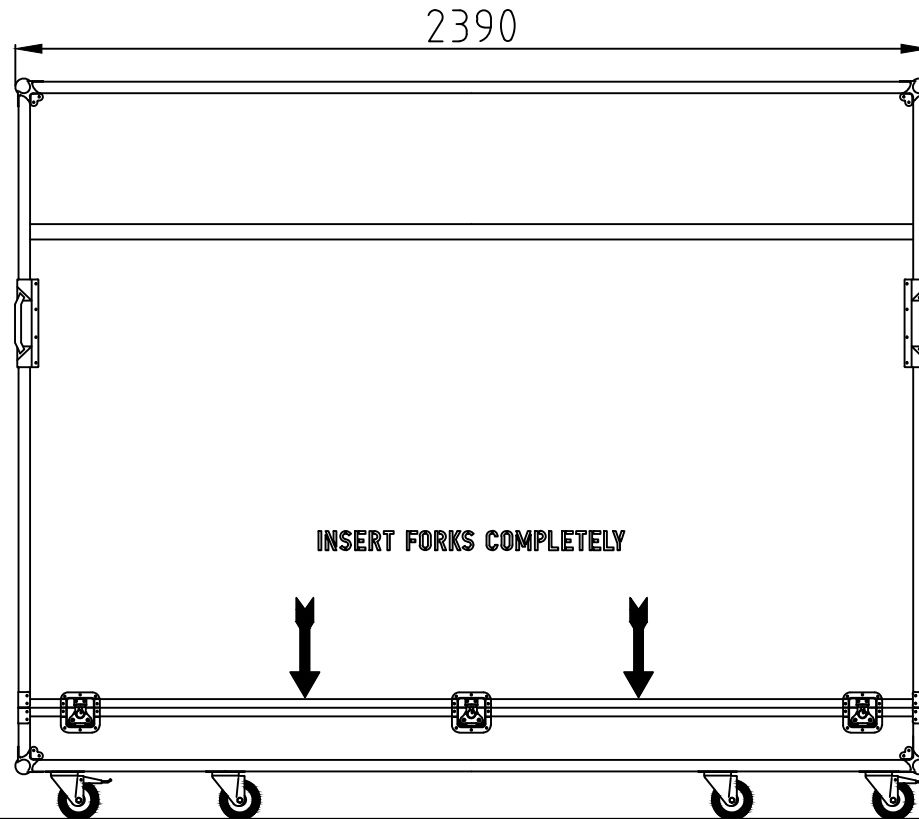
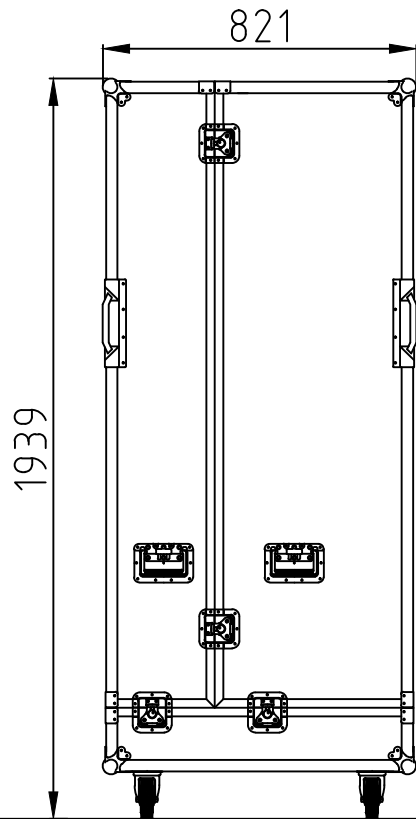

Projekt: SL98

Datum: 15.01.2015

**MEDIA SCREEN**

Name: Eidloth Th.

Tel: 089/697994-60

Fax: 089/697994-70