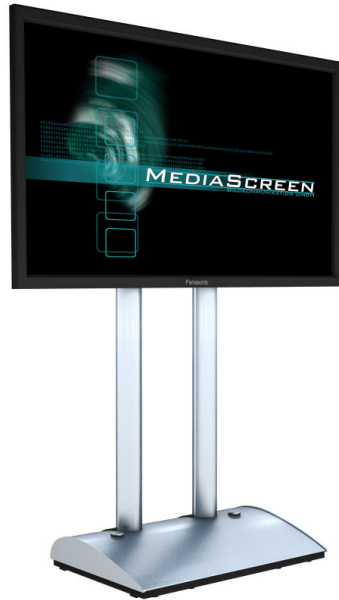

**SCREENLIFTER
103****DISPLAY SYSTEM**

Using the ScreenLifter 103, the handling and setup of the newest generation of 103" large screen displays becomes a mere child's play. At the touch of a button the up to 500 lb heavy display unloads itself from the flight case. Thanks to the precise heavy-duty lifting mechanism, the ScreenLifter 103 allows step less adjustment of the display height. The display can even be rotated into portrait orientation.

The ScreenLifter with its integrated shock absorbing system combines a secure and convenient storage and transport system with a stylish design stand that allows the tool-free setup of the display by just one person. The display is permanently attached to the ScreenLifter, which significantly reduces the risk of damage during handling and saves precious time and cost of labour.

No compromises were made in the development of the ScreenLifter 103 to meet the targets of perfect function and premium design. Its elegant and unobtrusive design makes the ScreenLifter 103 the perfect match for the exquisite Panasonic TH-103 plasma display.

The flight case fits through a standard door frame, which makes it possible to set up the ScreenLifter 103 in virtually any location. Setup and operation of the ScreenLifter 103 are entirely tool-free and made simple by the control unit's pre-programmed memory positions. The control panel features a LED display that shows the height of the bottom edge of the displayed image. A wired remote control is available as an optional accessory.

FEATURES & FUNCTIONS

- Aesthetic and functional design stand for 103" displays.
- Electrical self up- and unload function.
- Tool free setup by only 1 person in a few minutes.
- Secure transport system with shock absorbing system.
- Step less electrical height adjustment and 90° rotate function.
- Robust steel and aluminum construction.

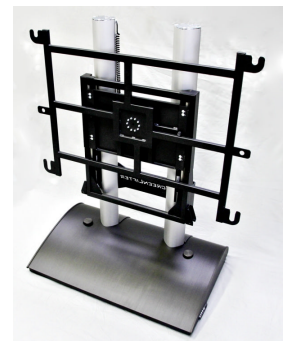

Transportcase SL103

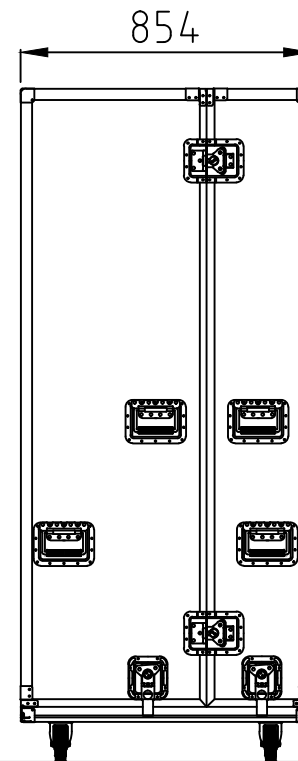
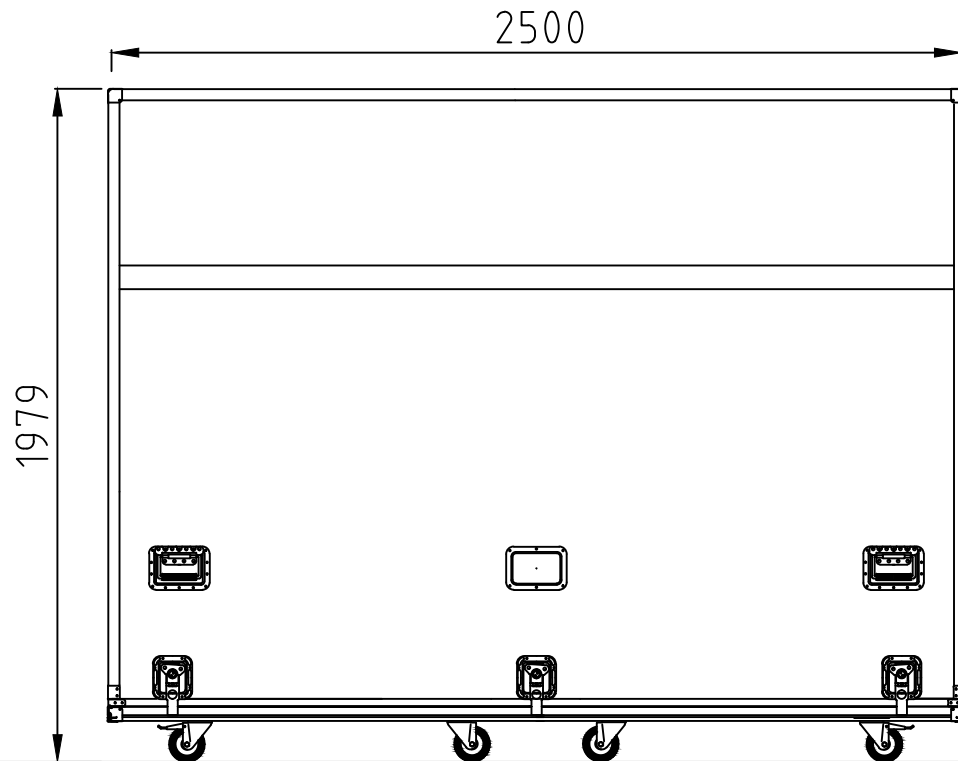

Case Leergewicht 214 kg
Gewicht ScreenLifter ca. 210 kg
Displaygewicht ca. 207 kg

ScreenLifter 103

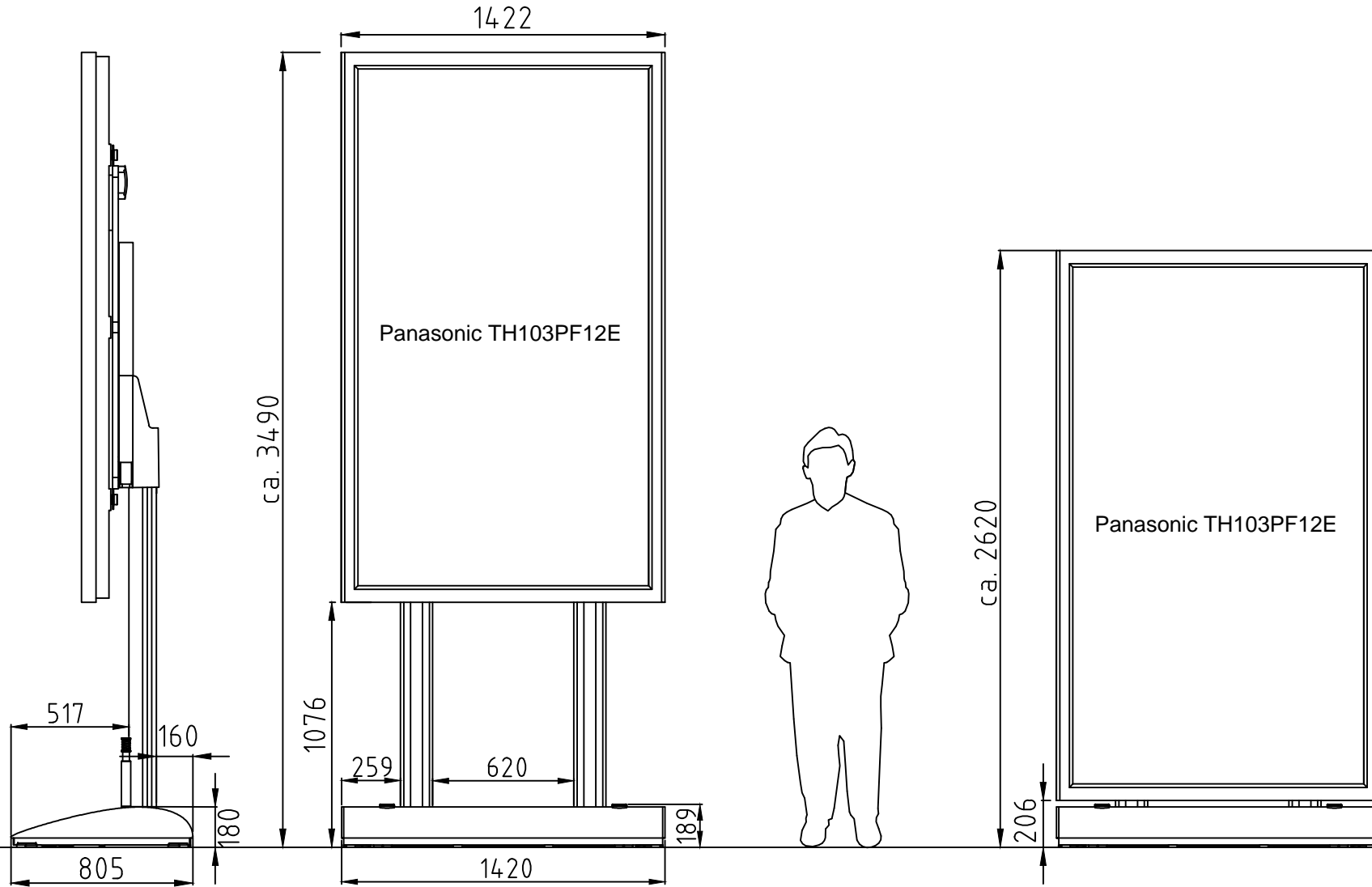

Projekt: SL103

Datum: 26.01.2012

MEDIA SCREEN

Name: Eidloth Th. Tel: 089/697994-60 Fax: 089/697994-70

ScreenLifter 103

